

WingS Kiosk

PATENTED - DESIGN MODEL N°. 2033

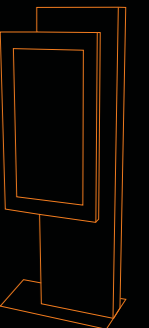

mail: info@pointkiosk.si . tel.: +386 (0)5 3305 771 . fax.: +386 (0)5 3305 495

WingS

Interactive Advertising

Technical Specifications WingS Kiosk

Dimensions: H1900 x W850 x D450
Weight: aprox. 80 Kg.

The WingS model was designed specially for outdoor applications with protection or indoors.

This model can be manufactured in stainless steel or painted steel (available in all RAL colors) using steel plate of 1,5mm to 2,5mm which ensures the stability and rigidity of the all structure.

This Kiosk is designed specially for multimedia advertising purposes and support large displays (32" to 108").

The area where the PC will be installed has security locks, general switch and is easily detachable, leaving enough space for the installation and access to a minitower PC.

On the side of the monitor are two speakers and the kiosk has 2 independent systems of ventilation, one for the monitor and other for the PC.

The WingS is normally equipped with a Atom CPU with a 160 GB hard drive, 1 Gb Ram Memory, a 128Mb graphic card and a 10/100 mb ethernet, Windows 7 Starter.

This kiosk can be produced with glass protection (top and 2 laterals) for



PATENTED - DESIGN MODEL N°. 2033

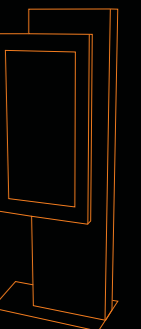

WingS

Distance comparison and main features

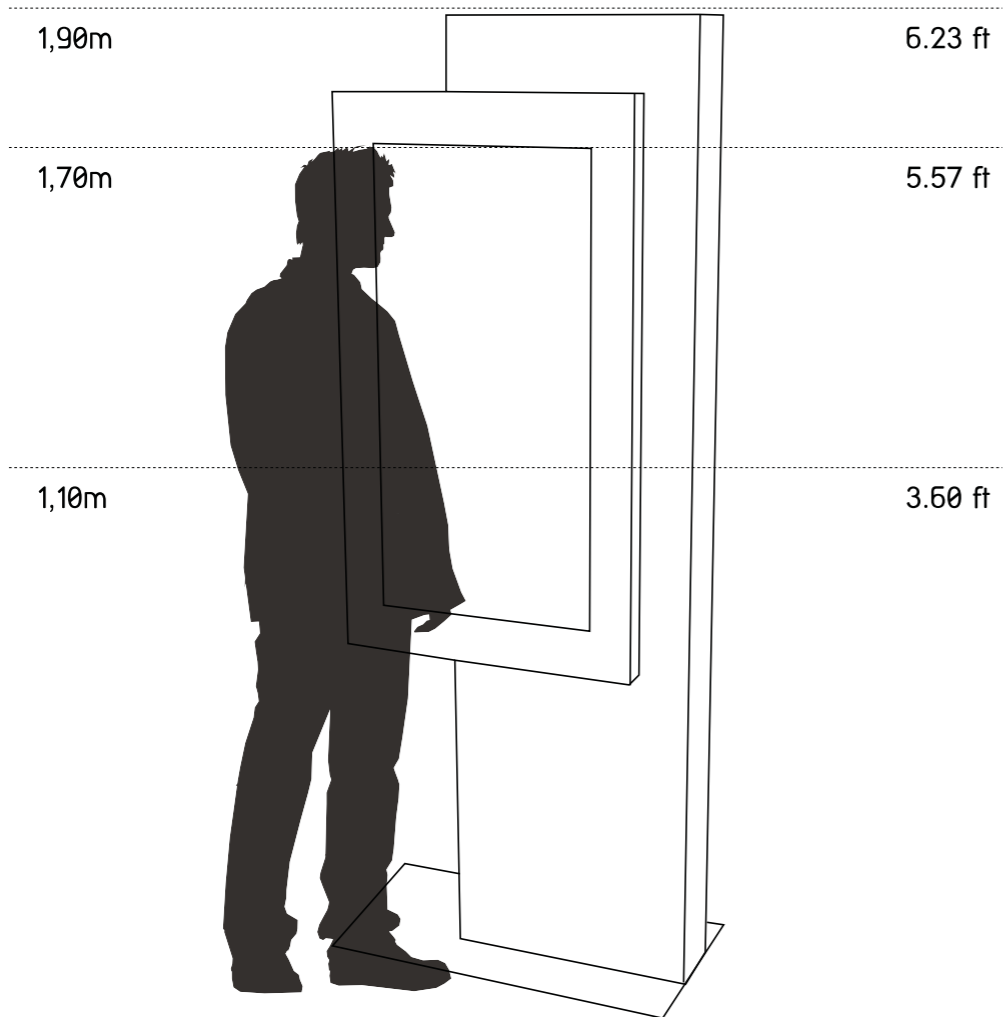

Type

- Indoor / Outdoor

Materials

- Painted Steel
- Stainless Steel

Options

- Large Displays 17" to 103"
- YdSignage Software
- Double Face Displays (Touchscreen or TFT)
- Glass Protection

Stylo
Distance comparison and main features

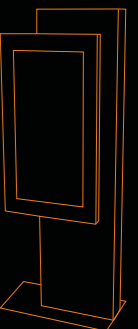

WingS

Kiosk measures

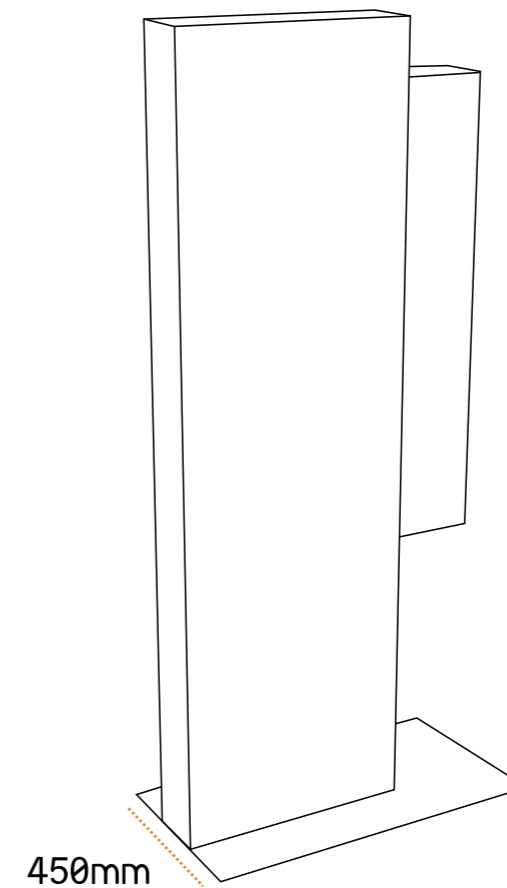
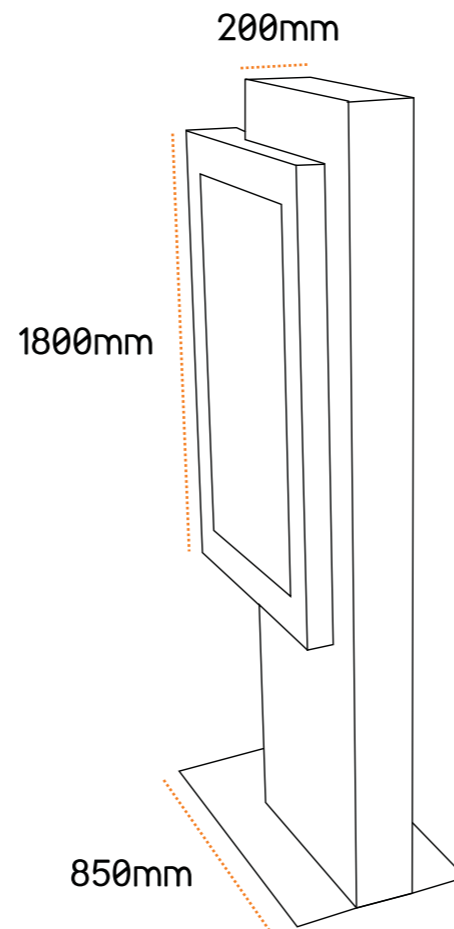
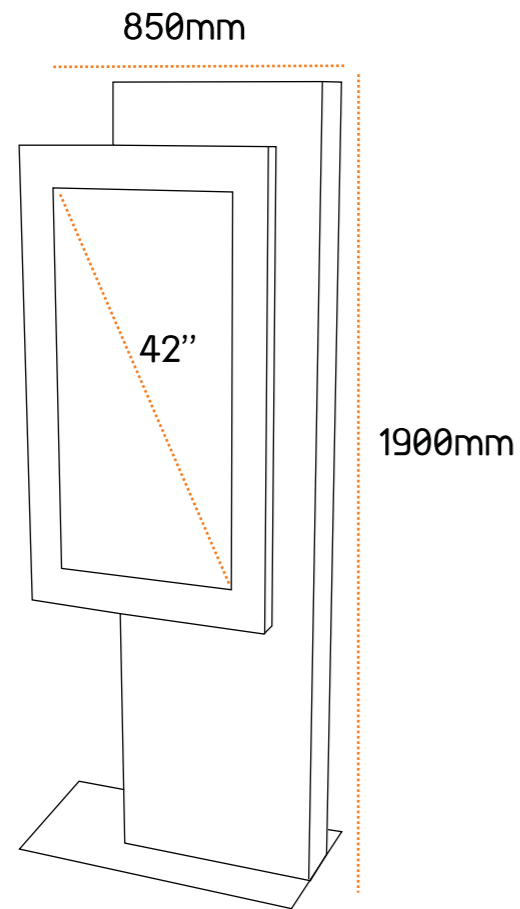

Kiosk measures
Stylo

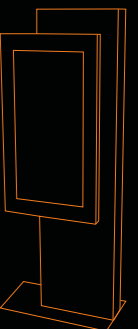

WingS

Technical data

Dimensions:

- 42" Display (resolution: 1920x 1080 Pixel)
- H1900 W850 D450

Weight:

80 kg

Configuration:

- Interactivity Advertising
- Stainless steel AISI304 or painted steel (RAL Colors)
- Steel plate of 1,5mm to 2,5mm
- 42" display
- Integrated speakers

Optional:

- 32" to 108" displays
- Atom or Dual Core PC computer
- Microsoft Windows 7 Professional
- Ykiosk software package
- Touchscreen
- Wireless networking - WLAN
- Bluetooth functionality
- Webcam
- 2 side displays

• Other components can be integrated changing kiosk dimensions: ticket printer, coin validator, bill validator, card readers, antivandalic keyboard, proximity sensor, etc.

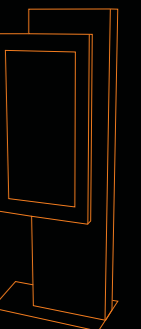



info@pointkiosk.si . tel.: +386 (0)5 3305 771 . fax.: +386 (0)5 3305 495

COBIT d.o.o., Industrijska cesta 5, Kromberk - p.p.235 -5001 Nova Gorica