

Ergo Kiosk



mail: info@pointkiosk.si . tel.: +386 (0)5 3305 771 . fax.: +386 (0)5 3305 495

Ergo

Ergonomic revolution

The Ergo model was developed for indoors use to work as stand up kiosk.

This model can be produced with or without de removable seat.

This model can be manufactured in stainless steel or painted steel (available in all RAL colors) using steel plate of 1,5mm to 2,5mm which ensures the stability and rigidity of the all structure.

The Ergo is normally equipped with a tactile monitor and can be delivered with a anti vandalic keyboard with trackball, card reader, webcam, coin acceptor, tickets printer, handset phone and other peripherals. This model can be equipped with a anti vandalic monitor.

For the union between the tactile monitor area and the PC area (possible printer area also) are used two polished tubes of 40x40x1,5 mm.

The peace that holds the monitor can be moved through a mecanic process to several positions in height, allowing the use of the kiosk by people standing ,wheel chair people and/or by children.

The Ergo Model is normally equipped with a Atom CPU with a 160 GB hard drive, 1 Gb Ram Memory, a 128Mb graphic card and a 10/100 mb ethernet, Windows 7 Starter.

Technical Specifications Ergo Kiosk

Dimensions: H1650 x W650 x D550
Weight: aprox. 65 Kg.



100% compatible
Front Use



Ergo

Distance comparison and main features

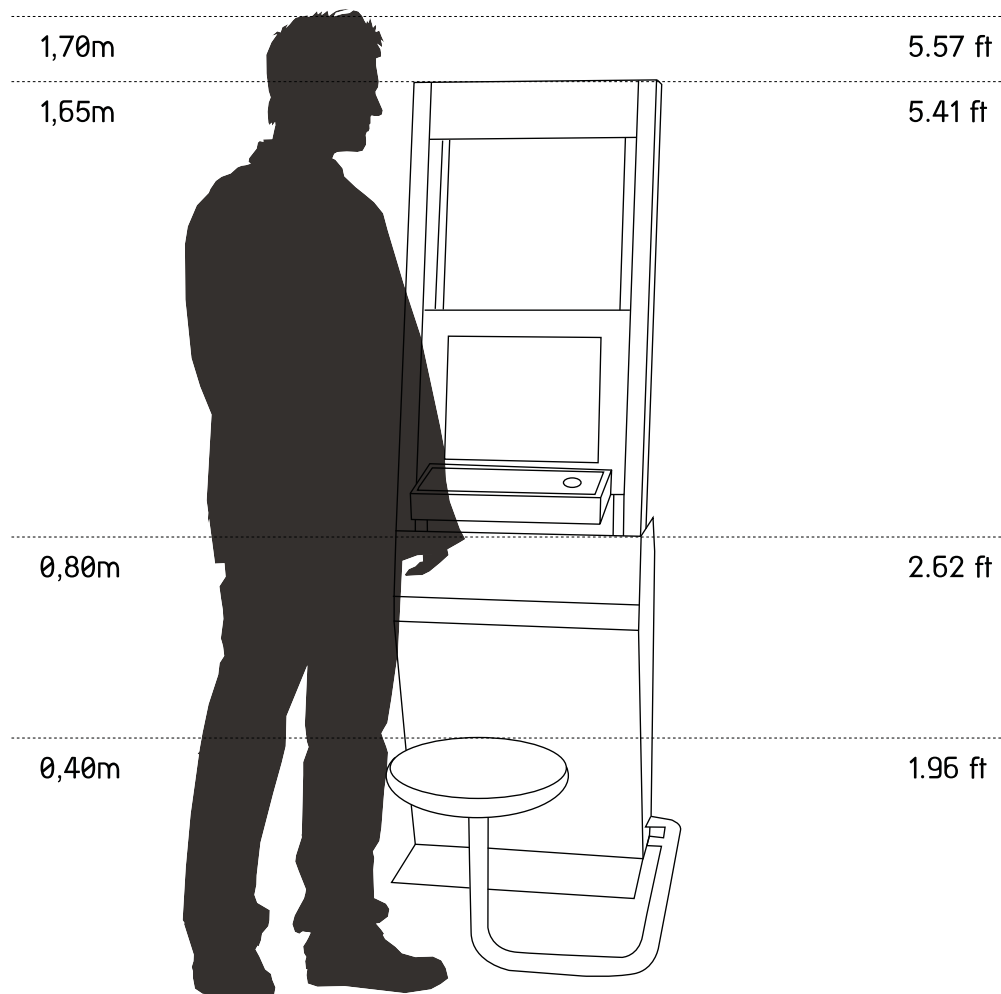

Type

Indoor

Materials

Painted Steel

Stainless Steel

MDF

Options

Webcam

Ticket Printer

Card Reader

Antivandalic Keyboard

Bar Code Scanner

Handset Phone

Coin Validator

Bill Validator

A4 Printer

Ykiosk Software



Ergo

Kiosk measures

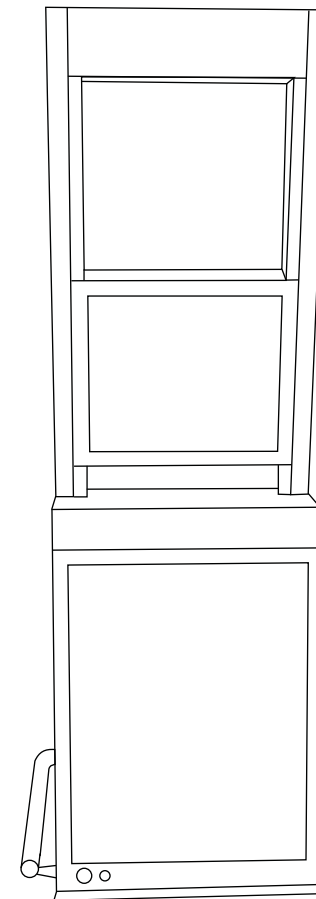
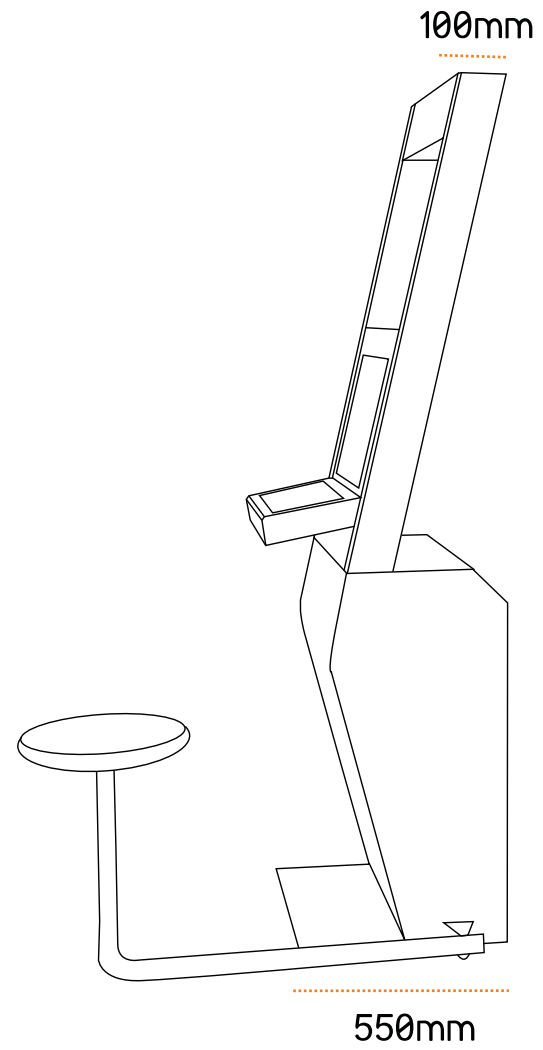
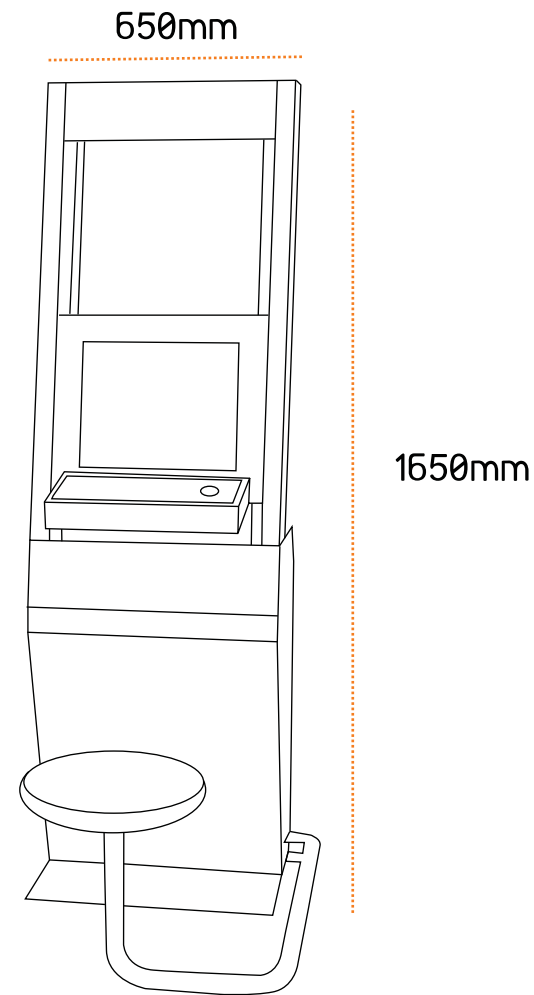

Ergo

Technical data

Dimensions:

- 17" Display (resolution: 1280 x 1024 Pixel)
- H1650 W650 D550

Weight:

65 kg

Configuration:

- Ergonomic Revolution
- Stainless steel AISI304 or painted steel (RAL Colors)
- Steel plate of 1,5mm to 2,5mm
- 17" touchscreen display (resistive)
- Integrated speakers

Optional:

- 19" to 24" Displays
- Atom or Dual Core PC computer
- Microsoft Windows 7 Professional
- Ykiosk software package
- Antivandalic Keyboard
- Touch screen (SAW - antivandalism)
- Wireless networking - WLAN
- Bluetooth functionality
- Webcam

• Other components can be integrated changing kiosk dimensions: ticket printer, coin validator, bill validator, card readers, antivandalic keyboard, proximity sensor, etc.





info@pointkiosk.si . tel.: +386 (0)5 3305 771 . fax.: +386 (0)5 3305 495

COBIT d.o.o., Industrijska cesta 5, Kromberk - p.p.235 -5001 Nova Gorica